

# ANALYSIS & SIMULATION OF 3 PHASE INVERTER FOR MOTOR DRIVE APPLICATIONS

C.NARENDRA<sup>1</sup>, D.NOORJAHAN BEGUM<sup>2</sup>, S.RAVINDRA ROYAL<sup>3</sup>, B.LAVANYA<sup>4</sup>,  
V.BRAMHAIAH<sup>5</sup>

<sup>5</sup>Guide

Department Of EEE

Tadipatri Engineering College, Tadipatri.

## Abstract:

In this work, a three-phase voltage switching inverter that uses Space Vector Pulse Width Modulation (SVPWM) to drive induction motors in three-wheel electric cars is designed, controlled, and analysed. Due to their affordability and environmental friendliness, induction motors are frequently utilized in electric vehicles in place of conventional fuel engines. Controlling the torque, speed, and direction of electric three-wheelers—such as Bajaj vehicles—is the main topic of this study. SVPWM is employed because it boosts efficiency, decreases ripple (fluctuations), and optimizes the utilization of battery power (DC). It accomplishes this by regulating the stator's voltage and frequency while maintaining a steady voltage-to-frequency ratio. MATLAB Simulink is used to develop and simulate models for the system's transfer function, vehicle dynamics, and inverter with SVPWM. The Arduino IDE serves as the control system as well. Important performance metrics are displayed and examined, including torque, speed, stator current, rotor current, and inverter switching patterns.

**Keywords:** Power supply, stepdown transformer, rectifier, capacitor, inductor, mosfet, diode, load.

## INTRODUCTION

Induction Machines are the most commonly utilized motors in industry as well as in residential applications. Their low cost, high efficiency, broad speed range, and durability enable induction motors to be used in various applications. Nowadays, in the majority of industrial applications, AC motors, due to their simple and highly robust construction without any mechanical commutator, are more advantageous than DC machines [1, 2]. In electric vehicle propulsion, a three-phase AC induction motor drive is powered by a three-phase inverter connected to a DC source or battery at roughly constant voltage, via a DC/AC inverter [3]. The DC/AC inverter consists of fast-switching power electronic switches and power diodes. IGBTs and MOSFETs are frequently employed in the inverter configurations. A high-speed processor is required to generate the appropriate switching sequence as the AC voltage output of the inverter takes the form of high-frequency square waves. To establish the amplitude and frequency of the output voltage, various switching schemes are employed to produce the PWM signal. Space Vector Pulse Width Modulation (SVPWM) is one of the several PWM techniques that is most suitable for electric vehicle applications [4]. This modulation method possesses several appealing features such as improved DC-link utilization, more efficient utilization of DC source voltage, reduced ripple, and enhanced lifespan of the drive [5]. The paper is organized as follows: the first section discusses the system description, the second presents the modeling aspects, the third covers power and control issues, and finally, the results obtained are shared along with the conclusions.

## RELATED WORK

Neeti Dubaj et al. (2019) provided an overview of the analysis of a bidirectional DC-DC boost converter with a quadrature converter for strength garage gadgets. In this overview, it is clear from the authors' evaluation that the bidirectional DC-DC buck-boost converter makes a more suitable system with power garage [1].

M. Sheng, D. Zhai, X. Wang et al., (2016) provided a review of the coordination of enterprise and shrewd marketplace for strength supply of hybrid inexperienced mobile community switches. In this article, they

stated that the grid-gear up, intermittent and erratically dispensed energy of the industry poses critical challenges in delivering mobile visitors at a given time throughout one-of-a-kind networks. The aim is to lessen the strength consumption of cell networks by means of using renewable energy and renewable energy. We gift this hassle as a nonlinear combined-integer programming problem, which has been demonstrated to be NP-hard [2].

E. Jimenez, M. J. Carrizosa, A. Benchebe et al., (2016) offered a overview of a brand new strength generation float approach for more than one DC networks linked together. In this review, the author's evaluation the mathematical motivation for this new electricity waft algorithm from this paintings, which ensures the lifestyles of a unique answer because the voltages technique the nominal cost. The new approach became also designed to be without problems adopted in AC structures [3].

J.Y. Yong, V.K. Ramachandramurthy et al. (2015) offered a assessment of a bidirectional EV fast charging station with reactive power benefit for voltage manipulate. In this overview, the author examines the voltage rise of high-pace electric powered cars on low-voltage distribution networks under top load conditions. Simulation consequences show that rapid charging of six EVs results in emissions beyond the safe operating voltage level [4].

Vitor Farno Pires, Danier Foito, Armando Cordeiro et al., (2017) Review of a DC-DC converter with bidirectional gain and bidirectional performance for batteries. In this paper, the author considers a bidirectional quadrupole converter particular to applications requiring a financial institution of electrical strength garage devices together with batteries or supercapacitors [5].

Dason-Anjing, Chun-Soko, Guo-Guang Zhen et al., (2013) provided a assessment of a Cockcroft-Walton voltage amplifier cascade utilized in a transformer with a excessive-level DC-DC converter. In this evaluation, in destiny paintings, the writer considers the weight impact on the output voltage of the proposed converter, which desires to be managed to perform a constant-state evaluation [6].

Seyed Hossein, Resq Ghazi, Hamad-Haydari et al., (2019) offered a review of a scalable bidirectional quadrupole DC-DC converter. In this assessment, the writer examines the complexity of the desk construction. Complex small signal, high sensitivity, obligation cycle depending on the benefit [7].

Juqiu, Xuan, Yan Bao, Leiyiwan et al. (2014) supplied a evaluation of bidirectional converter topologies for power alternate among EVs and the grid. In this evaluation, the writer studied its operating ideas and methods to perform and resolve the energy troubles [8].

## EXISTING SYSTEM

Motor control systems frequently employ traditional PWM approaches, such as hysteresis control and sinusoidal PWM (SPWM). Although these systems are simpler to install, they have increased torque ripple and inefficient DC voltage consumption.

### *Disadvantages*

- Higher output voltage and current ripple; inefficient use of the DC supply.
- A decrease in motor efficiency due to increased losses.

### **Proposed System**

SVPWM is used in the suggested system to regulate a three-phase voltage source inverter that powers an induction motor. This technique offers smoother control over motor torque and speed, lowers harmonic content, and increases voltage consumption.

**BLOCK DIAGRAM**

The PIC micro-controller is used to implement the hardware system of the suggested converter. The system design for coding the pulses into the PIC controller uses software such as Proteus, Mplab, and Micropro. In order to drive the pulses to the MOSFET, the power supply circuit is made to regulate the PIC and driver circuit.

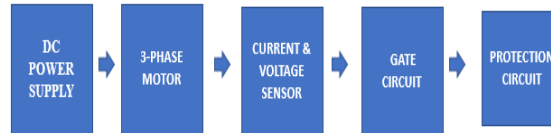

**System Requirements**

*Hardware Requirements*

**MICROPRO:**

This versatile programmer specializes in programming PIC microcontrollers. This hardware can be used to program any PIC series of ICs, with the exception of the 17 series, over the PC's RS232 port. For onboard programming of compatible flash PIC devices, this programmer furthermore supports ICSP programming. The CD-ROM contains the MPLAB IDE, the PIC CCS C compiler demo software, the MPLAB Plug-in, and programming instructions. The operating systems Windows 98, 2000, and XP are all compatible with the programming software. In addition to the printed copy that comes with the Kit, the CD also includes a soft copy of the user manual. Programming a variety of PIC Micro controllers, such as EEPROMS, PIC12, PIC16, and PIC18 series of ICs, is the responsibility of this dedicated programmer.

**CONTROLLER UNIT:**

A microcontroller is a tiny computer on a single integrated circuit that has a CPU core, memory, and programmable input/output peripherals. It is sometimes shortened to  $\mu$ C, uC, or MCU. Along with a usually little quantity of RAM, program memory in the form of NOR flash or OTP ROM is also frequently placed on chip. Unlike microprocessors found in personal computers or other general-purpose applications, microcontrollers are made for embedded applications.

Because of its low cost, widespread availability, broad user base, comprehensive library of application notes, availability of free or inexpensive development tools, and ability to serially program (and re-program with flash memory), PICs are popular among both industrial developers and amateurs. In September 2011, Microchip declared that their ten billionth PIC processor was on its way.

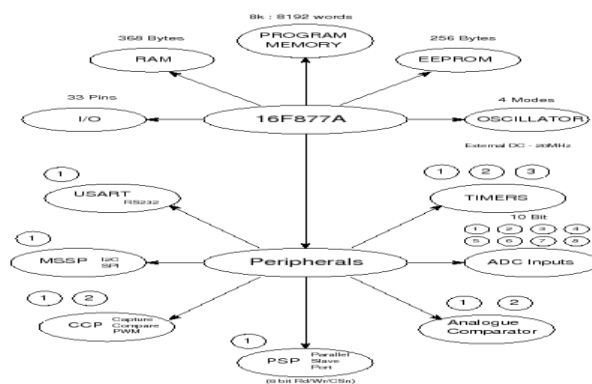

**Fig 2: Micro-controller Peripherals**

**Peripheral Details:**

Timer0: 8-bit prescaler and timer/counter Timer1: a 16-bit timer/counter with a prescaler that may be increased while you sleep by using an external clock or crystal. Timer2: 8-bit timer/counter featuring a prescaler, postscaler, and 8-bit period register Two modules for capture, comparison, and PWM Resolution is 12.5 ns, maximum capture is 16 bits. Synchronous Serial Port (SSP) with SPI (Master mode) and I2C

(Master/Slave) with a maximum resolution of 16 bits and a maximum resolution of 200 ns; Universal Synchronous Asynchronous Receiver Transmitter (USART/SCI) with a 9-bit address detection; Parallel Slave Port (PSP) with an 8-bit width and external RD, WR, and CS controls (40/44-pin only); and Brown-out detection circuitry for Brown-out Reset (BOR).

**Special Microcontroller Applications:**

100,000 cycles of writing and erasing Enhanced Flash program memory with a normal erase/write cycle of one million Typical data EEPROM memory More than 40 years of data EEPROM retention software-controlled self-reprogramming capability, Serial programming in-circuit using two pins, With its own on-chip RC oscillator for dependable operation, the 5V In-Circuit Serial Programming Watchdog Timer (WDT) requires only one source. Protection of programmable code, Sleep mode, which saves power, two pins are used for In-Circuit Debug (ICD) and oscillator selection.

**CMOS Technology:**

Fast, low-power Flash/EEPROM technology, completely static design, broad operational voltage range (2.0V to 5.5V), temperature ranges for commercial and industrial settings, little power usage.

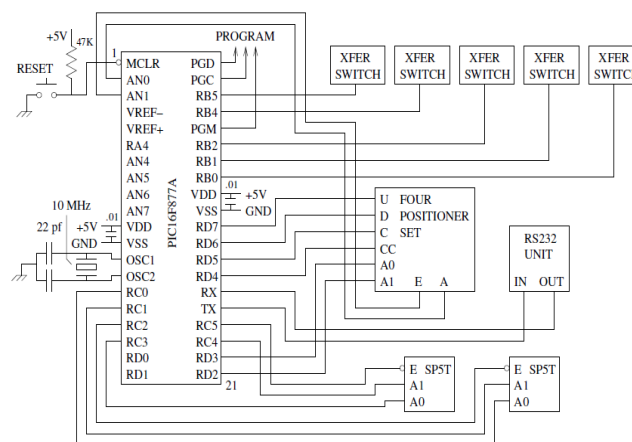

**Fig 3: Microcontroller PIC16F877A**

**MOSFET GATE DRIVER:**

With separate high and low side referenced output channels, the High And Low Side Driver (IR2112) is a high voltage, high speed power MOSFET and IGBT driver. Ruggedized monolithic construction is made possible by proprietary HVIC and latch immune CMOS technology. Up to 3.3V logic, logic inputs can be used with conventional CMOS or LSTTL outputs. A high pulse current buffer step in the output drivers is intended to minimize driver cross conduction. Matching propagation delays makes high frequency applications easier to operate. An N-channel power MOSFET or IGBT operating at 600 volts in the high side configuration can be driven by the floating channel.

In this project, the converter functions as a shunt active filter (2-quadrant) for unity power factor operation and dc voltage regulation, and the driver circuit is utilized to drive the bi-directional converter switches. The n-type and p-type BJTs are employed for amplification in this case.

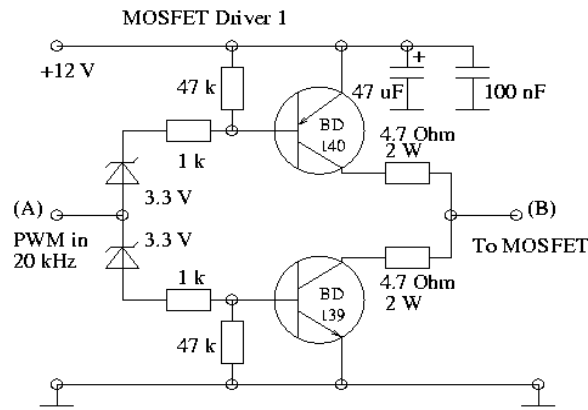

Fig 4: DRIVER CKT IR2110

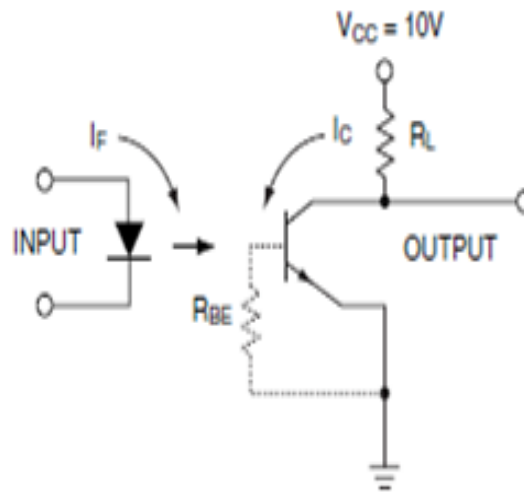

Fig 5: Operation of the MOSFET gate driver

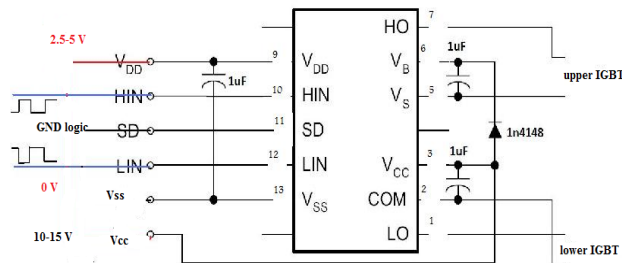

Fig 6: Driver Circuit operation



Fig 7: IR2110 Driver

## MOSFET

A cross section of an n-MOSFET when the gate voltage  $V_{GS}$  is below the threshold necessary for creating a conductive channel; there is minimal or no conduction between the source and drain terminals; the switch remains off. When the gate becomes more positive, it draws in electrons, leading to the formation of an n-type conductive channel in the substrate beneath the oxide, which permits the flow of electrons between the n-doped terminals; the switch is now on.

The metal–oxide–semiconductor field-effect transistor (MOSFET, MOS-FET, or MOS FET) is a type of transistor employed for amplifying or switching electronic signals. The fundamental concept behind this transistor type was first patented by Julius Edgar Lilienfeld in 1925. Twenty-five years later, when Bell Telephone sought to patent the junction transistor, they discovered that Lilienfeld already possessed a patent that was phrased in a manner that encompassed all varieties of transistors. Bell Labs managed to reach an agreement with Lilienfeld, who was still alive during that period. (It remains unknown whether they compensated him financially or not. ) At that time, the Bell Labs version was named the bipolar junction transistor, or simply junction transistor, while Lilienfeld's design was termed field effect transistor.

An insulated-gate field-effect transistor or IGFET is a related term that is nearly synonymous with MOSFET. The term might be broader, given that many "MOSFETs" utilize a gate that may not be metallic and a gate insulator that may not be an oxide. Another alternative term is MISFET for metal–insulator–semiconductor FET. Generally, the semiconductor of choice is silicon, but some chip manufacturers, particularly IBM and Intel, have recently begun using a chemical compound of silicon and germanium (SiGe) in MOSFET channels. Unfortunately, numerous semiconductors that possess superior electrical characteristics compared to silicon, such as gallium arsenide, do not create effective semiconductor-to-insulator interfaces, rendering them unsuitable for MOSFETs. Ongoing research is focused on developing insulators with appropriate electrical properties on alternative semiconductor materials.

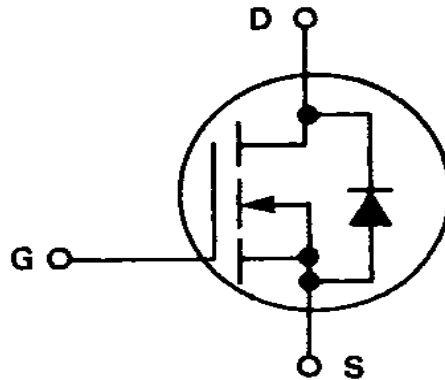

*Fig 8: MOSFET*

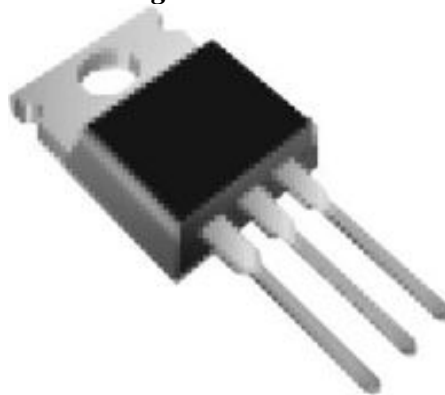

*Fig 9: IRF840*



PRODUCT SUMMARY	
$V_{DS}$ (V)	500
$R_{DS(on)}$ ( $\Omega$ )	$V_{GS} = 10\text{ V}$   0.85
$Q_g$ (Max.) (nC)	63
$Q_{gs}$ (nC)	9.3
$Q_{gd}$ (nC)	32
Configuration	Single

Fig 10: Product Summary

Vishay's third generation Power MOSFETs provide designers the best possible balance of low on-resistance, ruggedized device design, quick switching, and affordability. For all commercial-industrial applications with power dissipation levels up to about 50 W, the TO-220AB package is universally recommended. The TO-220AB is widely used in the industry because of its low packaging cost and low thermal resistance.

This advanced power MOSFET, which operates in the breakdown avalanche mode, is an N-Channel enhancement mode silicon gate power field effect transistor that has been built, tested, and proven to withstand a certain amount of energy. Applications for all of these power MOSFETs include motor drivers, relay drivers, switching regulators, switching converters, and drivers for high power bipolar switching transistors that need low gate drive power and high speed. Integrated circuits can be used directly to operate these kinds.

**DIODE:**

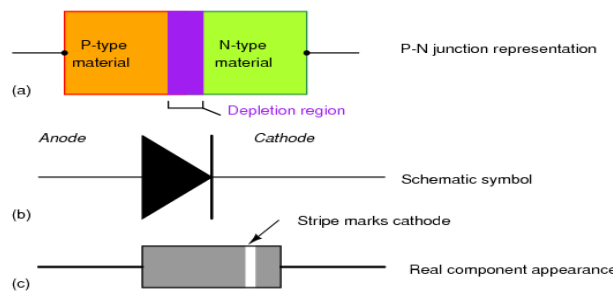

Fig 11: Diode

**INDUCTOR**

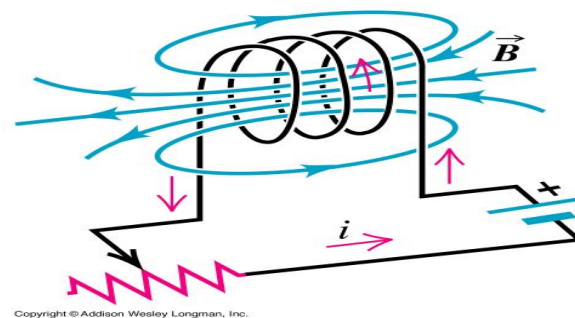

Fig 12: Inductor

A passive, two-terminal electrical component used to store energy in a magnetic field is called an inductor, reactor, or coil. Although the wire is usually twisted in loops to strengthen the magnetic field, all conductors have inductance. Faraday's law of electromagnetic induction states that a voltage is induced as a result of the coil's time-varying magnetic field, and Lenz's law states that this voltage is opposite to the change in current that produced it. Because they can delay and bend alternating currents, inductors are one of the fundamental parts used in electronics where voltage and current fluctuate over time. Chokes are inductors that can be used to prevent AC signals from flowing through a circuit or as components of filters in power supplies. In some switched-mode power supply, the energy storage component is an inductor. A certain percentage of the regulator's switching frequency is used to energize the inductor, which is then de-energized for the rest of the cycle. The input-voltage to output-voltage ratio is established by this energy transfer ratio. To maintain extremely precise voltage control, this XL is used in conjunction with an active semiconductor device.

## CAPACITOR



*Fig 13: Capacitor*

A passive, two-terminal electrical component used to store energy in an electric field is called a capacitor (previously called a condenser). Practical capacitors come in a broad variety of shapes, but they all have at least two electrical conductors divided by an insulator, or dielectric. For instance, a common design uses metal foils separated by a thin layer of insulating film. In many everyday electrical devices, capacitors are utilized as components of electrical circuits. A static electric field forms across the dielectric when there is a potential difference (voltage) between the conductors, which results in the accumulation of positive charge on one plate and negative charge on the other. The electrostatic field stores energy. One constant value, capacitance, expressed in farads, defines an ideal capacitor. This is the proportion of each conductor's electric charge to the potential difference between them. Capacitor conductors are frequently referred to as "plates," a reference to an earlier method of construction, because the capacitance is highest when there is a small space between large regions of conductor. In reality, a breakdown voltage is produced by the dielectric between the plates passing a tiny amount of leakage current and having a limit on the strength of the electric field, while the conductors and leads introduce resistance and an unwanted inductance. In electronic circuits, capacitors are frequently used to smooth the output of power supplies, filter networks, resonant circuits that tune radios to specific frequencies, and to block direct current while permitting alternating current to flow.

### *Software Implementation*

#### **MATLAB**

MATLAB® is a high-degree technical computer language and interactive surroundings for algorithm improvement, facts visualization, statistics evaluation, and numerical computation. Using MATLAB, you may clear up engineering pc problems faster than with conventional programming languages consisting of C, C++, and Fortran. MATLAB is an evaluation and visualization device that provides sturdy aid for matrices and matrix operations. In addition, Matlab has extraordinary portraits skills and its personal effective programming language. One of the motives why Matlab is this kind of precious device is using Matlab software packages designed to guide a specific project. These varieties of software program are referred to as toolkits, and precise toolkits are inquisitive about image processing gear. Rather than describe all the abilities of Matlab, we can restrict ourselves to the features relevant to photograph processing. We will introduce capabilities, instructions, and techniques as wished. The correct characteristic is a key-word that takes several parameters and produces some output, together with a matrix, string, graph, and so forth. Examples of such functions are sin, imprint, and closed. There are many correct functions, and as we are able to see, it is very smooth (and on occasion important) to jot down your very own.

The trendy Matlab data kind matrix all is a information type that may be handled as a type of array. However, snap shots are organized as factors whose factors are the gray values (or possibly RGB values) in their elements. If the order of the characters is correct, then correct every cost as it appears; the period of a string



is the period of a wire. We will see more Matlab commands in this bankruptcy, and in later chapters we are able to talk snap shots.

When you begin Matlab, you may have an empty window called window\_ where you enter instructions. Considering the massive number of Matlab capabilities and the various parameters they can take, a command line style interface is an awful lot greater efficient than a complicated drop-down menu. MATLAB may be used in a ramification of programs, consisting of sign and picture processing, communications, layout, take a look at and measurement, financial modeling, and evaluation. Additional toolkits (units of unique MATLAB functions) are available inside the MATLAB surroundings to resolve precise styles of issues in these application regions.

MATLAB offers many features for documenting and distributing your paintings. You can link your MATLAB code with different languages and applications, and distribute your MATLAB algorithms and programs. When running with snap shots in Matlab, there are many things to recall, along with loading photos, the usage of the right format, storing exclusive types of records, a way to show pictures, and converting among exclusive photo codecs.

The Image Processing Toolbox affords a entire set of algorithmic and graphical gear for image processing, analysis, visualization, and set of rules development. You can perform image enhancement, picture de-blurring, feature detection, noise reduction, photograph segmentation, spatial transformation, and picture registration. Many of the obligations in the toolkit are multi-threaded, allowing you to use multi-middle and multi-processor computers.

## CONCLUSION

The boost-buck DC–DC converter has been proposed in this research. Calculations have been made to compare the converter's performance with current topologies in terms of output voltage ripple ( $\Delta V_0$ ), output current ripple ( $\Delta I_0$ ), and input current ripple ( $\Delta I_i$ ). It is possible to infer from the analysis that the recommended architecture has decreased input current ripple, low output voltage ripple, and low output current ripple. As a result, the converter's efficiency is increased, making it an excellent choice for battery charging applications. The suggested topology's design equation and operation have been covered. A model prototype has been created and put to the test. Simulation results are used to validate the hardware results.

## REFERENCES:

1. Kailaswar, S.V., Keswani, R.A.: Speed control of three induction motor by V/F method for batching motion system. *Int. J. Eng. Res. Appl. (IJERA)* 3(2), 1732–1736 (2013). ISSN 2248-9622
2. Pawar, H.P., Chavan, N.S., Shinde, A.B., Chavan, Y.S.: Speed control of induction motor using PWM technique. *Int. J. Eng. Res. Technol. (IJERT)* 4(04), 174–177 (2015). ISSN 2278-0181
3. Soni, S.K., Gupta, A.: Analysis of SVPWM based speed control of induction motor drive with using V/F control based 3 level inverter. *IJSET* 2(9), 932–938 (2013)
4. Tabbache, B., Kheloui, A., Benbouzid, M.E.H.: Design and control of the induction motor propulsion of an electric vehicle. In: 2010 IEEE Vehicle Power and Propulsion Conference (VPPC), 1–3 September 2010, pp.1–6 (2010)
5. Kumar, K.V., Michael, P.A., John, J.P., Kumar, S.S.: Simulation and comparison of SPWM and SVPWM control for three phase inverter. *ARNP J. Eng. Appl. Sci.* 5(7), 61–74 (2010)
6. Manivannan, S., Veerakumar, S., Karuppusamy, P., Nandhakumar, A.: Performance analysis of three phase voltage source inverter fed induction motor drive with possible switching sequence execution in SVPWM. *Int. J. Adv. Res. Electr. Electron. Instr. Eng.* 3(6), 10081–10104 (2014). ISSN (Print): 2320–3765
7. Asma, N.R.L., Suresh, J.: Implementation of space vector pulse width modulation using arduino. *Int. J. Sci. Res.* (2012). ISSN (online): 2319-7064 Impact factor: 3.358
8. Van Der Broeck, H.W., Skudelny, H.-C., Stanke, G.V.: Analysis and realization of pulse width modulator based on voltage space vectors. *IEEE Trans. Ind. Appl.* 24(1), 142–150 (1988)

9. Zeraouila, M., Benbouzid, M.E.H., Diallo, D.: Electric motor drive selection issues for HEV propulsion systems: a comparative study. In: 2005 IEEE Conference on Vehicle Power and Propulsion, 7–9 September 2005, pp. 8–15 (2005)
10. Chauhan, S.: Motor torque calculations for electric vehicle. *Int. J. Sci. Res.* 4(08), 126–127 (2015)
11. Rachid, M.H.: *Power Electronics: Circuits, Devices, and Applications*. 3rd edn. (2004)
12. El-Saady, G., Ibrahim, E.-N.A., Elbesealy, M.: V/F Control of three phase induction motor drive with different PWM techniques. *Innov. Syst. Design Eng. IISTE* 4(14), 131–144 (2013)